

UD2V-P45

Ultrasonic Flow Detector

Operating Manual



KROPUS
Copyright 1998-2003 Kropus

Important Notice

Please read the following information prior to use of any ultrasonic Kropus instrument.

General Warning

The correct and effective use of ultrasonic test equipment requires the interaction of three essential factors:

- The test equipment itself
- The specific test applications
- The operator

The principal purpose of this operating manual will be to give instructions in the basic set-up and functional operation of the test equipment. Other variable factors are the responsibility of the customer/user. Details regarding these factors are beyond the scope of the operating manual.

Ultrasonic Theory

Basic conceptions of soundwave propagation theory, including the effects of sound velocity, attenuation, reflection, refraction and the limitation of the sound beam must be understood by the operator.

Training

The customer must provide for adequate training of the operators to assure competence in the operation of the equipment and in the associated factors. The operator must be trained both in general ultrasonic testing procedure and in the set-up and performance of a particular test or application.

Test Application Requirements

Customer engineers should supply specific test application requirements to the operator. These requirements include a definition of the test problem, selection of suitable techniques, adequate probes, evaluation of discovered conditions in the test material, and the selection of acceptance or rejection limits.

Coverage and Location of Test

Selection of test locations and degree of coverage of the part, is based on customer knowledge of expected defective areas, material being tested, environment and similar factors.

Flaw Size Evaluation

There are, basically, two methods of assessing flaws.

- **Flaw Boundary Method:** If the diameter of the sound beam is smaller than the spread of the flaw, then the beam can be used to search the flaw boundaries to determine its area. The smaller the diameter of the sound beam, the more accurately the boundaries can be determined. If, however, the sound beam is relatively broad, the flaw area determination can differ from the actual.
- **Echo Comparison Method:** If the diameter of the sound beam is greater than the spread of the flaw, the maximum echo response from the flaw must be compared with the maximum echo response from an artificial flaw provided for comparison purposes. The echo from a small natural flaw is usually smaller than the echo from an artificial comparison flaw of the same size. This fact due to indirect orientation or irregular shape of the flaw surface, and should be considered when evaluating flaw size to avoid underestimating size.

Specifications and Procedures

The customer must understand and provide for interpretation and compliance with the specifications covering its work, generated by such groups as in-house Quality Assurance, Technical Societies, Industry Groups, or Government Agencies.

Ultrasonic Thickness Measurements

Ultrasonic thickness measurements are the result of the mathematical product of the velocity of sound in a material and the transit time of the soundwaves through the material. The transit time is the data obtained by the ultrasonic equipment.

Velocity of Sound

The accuracy of ultrasonic thickness measurements and of flaw location depends to a major degree on the velocity of sound through the material. This velocity value is dependent mainly from physical characteristics of test material and its temperature. Any non-uniformity of sound velocity in the test material may result in erroneous thickness measurements.

Temperature Dependence

Velocity of sound is affected to varying degrees by the temperature of the material. When temperature variables are expected, frequent checks must be made to maintain instrument calibration for the changing test conditions.

CONTENCE

<p>1. Understanding the Keypad, Menu System, and Displays 4</p> <p> 1.1 Battery Installation 4</p> <p> 1.2 Powering On and Off the Instrument 4</p> <p> 1.3 Keypad Features 5</p> <p> 1.4 UD2V-P45 Menus and Functions 5</p> <p> 1.4.1 Main Menu System 6</p> <p> 1.4.2 Additional Menu System 8</p> <p> 1.5 Display Screen Features 10</p> <p> 1.6 Features of the UD2V-P45 11</p> <p>2. Set Up and Calibration of the UD2V-P45 11</p> <p> 2.1 Initial Instrument Setup 12</p> <p> 2.1.1 Display Appearance..... 12</p> <p> 2.2 Installing a probe..... 13</p> <p> 2.2.1 Connecting a probe..... 13</p> <p> 2.2.2 Configuring the Instrument to Match the Probe Type..... 13</p> <p> 2.3 Adjusting the A-scan..... 16</p> <p> 2.3.1 Setting the A-Scan Range... 16</p> <p> 2.3.2 Setting the Display Delay.... 16</p> <p> 2.3.3 Selecting the Pulser Repetition Frequency Mode..... 16</p> <p> 2.3.4 Selecting a Rectification Mode..... 16</p> <p> 2.3.5 Setting the A-Scan REJECT Level..... 17</p> <p>3. Configuring Your Instrument for Measurement 18</p> <p> 3.1 Configuring the a- and b-Gates.... 18</p> <p> 3.1.1 Positioning Gates..... 18</p>	<p> 3.1.2 Selecting the Gate Detection Method..... 19</p> <p> 3.1.3 Setting Gate Alarms..... 19</p> <p> 3.1.4 Setting the Horn mode..... 19</p> <p> 3.1.5 Settings the Displaying Measure 20</p> <p> 3.1.6 Settings the Measurement Mode 20</p> <p> 3.2 Using Angle Beam Probes 20</p> <p> 3.3 Saving the Instrument Configuration In Data Set 20</p> <p>4. Using the Instrument during test operations 22</p> <p> 4.1 Setting the Gain 22</p> <p> 4.1.1 Changing the Gain-Adjustment Increment (dB STEP) 22</p> <p> 4.2 Using the dB Reference Feature 22</p> <p> 4.3 Saving the measurement results 22</p> <p> 4.4 Magnifying the Contents of the A-Gate 22</p> <p>5 DAC/TCG Feature 23</p> <p> 5.1 Using TCG 23</p> <p> 5.1.1 Recording the TCG Reference Points 23</p> <p> 5.1.2 Working with TCG 23</p> <p> 5.2 Using DAC 24</p> <p> 5.2.1 Recording the DAC Curve 24</p> <p> 5.2.2 Working with DAC 25</p> <p> 5.3 Editing DAC Curve and TCG Reference Points 25</p>
--	---

1. Understanding the Keypad, Menu System, and Displays

The UD2V-P45 is an ultrasonic flaw detection and thickness measurement instrument. It's capable of storing A-Scans, operating parameters, and a variety of thickness-measurement data. This chapter of manual will help you understand the menu structure and know about functions of instrument.

In this chapter, you'll learn how to

- Install Batteries in the instrument
- Power up the instrument
- Understand the function of each key on the keypad
- Access each UD2V-P45 function using the built-in menu system
- Interpret the symbols that most often appear on the display
- List the features of the UD2V-P45

1.1 Battery Installation

The UD2V-P45 operates on four D-size or four C-size (optional) batteries, located in the rear of the housing, or by using 9-12V AC power adapter (figure 1-1). To remove/install the battery compartment cover, use the two thumb-screws. It's recommended that you install 7.0 Ahr rechargeable NiMh (Nickel Metal Hydride) batteries but the instrument will accept alkaline and rechargeable NiCad batteries. Whichever type of batteries you install, be sure to properly align the batteries' poles as marked in the battery compartment.

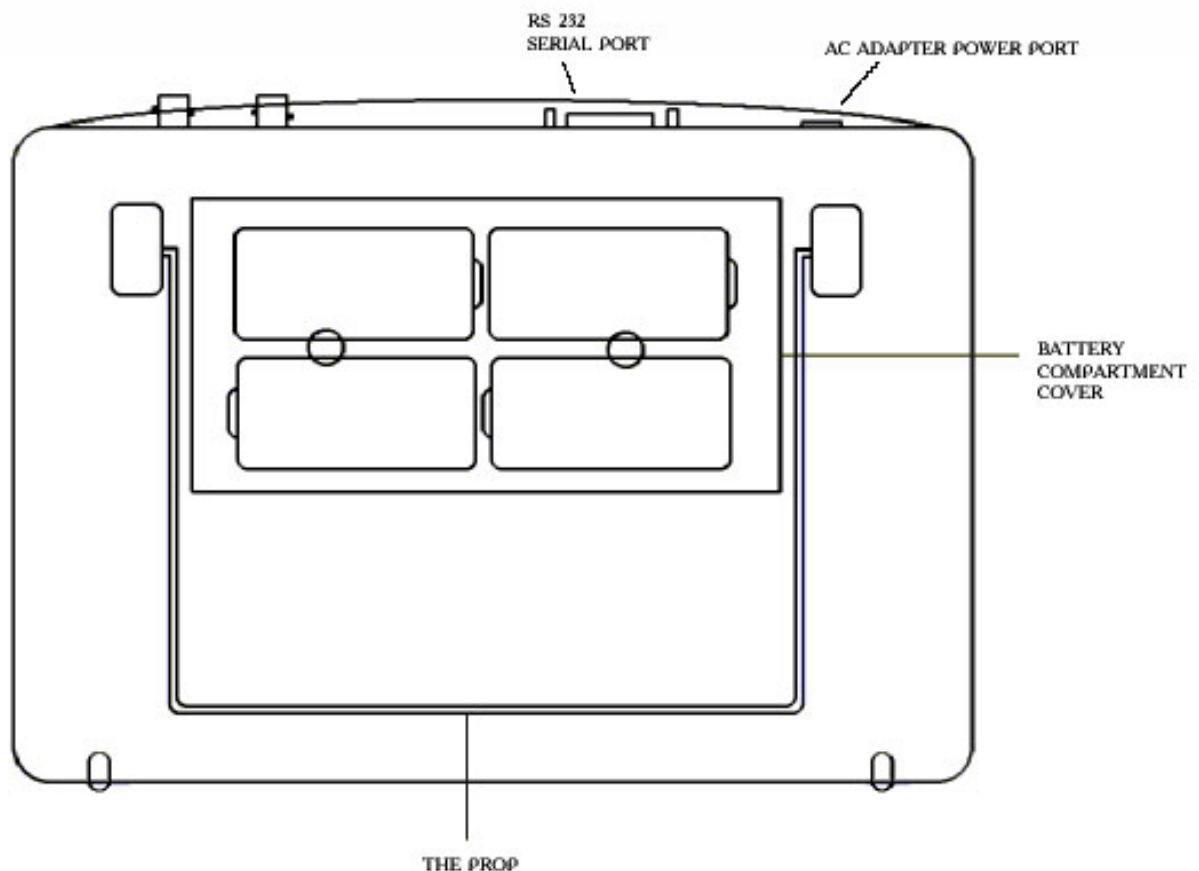



Figure 1-1 Rear view of instrument

NOTE: Your instrument was supplied with four rechargeable batteries.

To charge the batteries you need to remove the batteries from compartment cover and install into universal battery charger (optional). Refer to Charger's Operation Manual for a complete explanation of how to charge the batteries.

The approximate level of remaining battery life is visually displayed by the  icon. When fresh batteries are installed, the icon will appear as "full". As the battery life is consumed, the icon will begin to "empty."

NOTE: When batteries are too weak for reliable operation, the special symbol appears on display. If it occurs, replace the batteries as soon as possible.

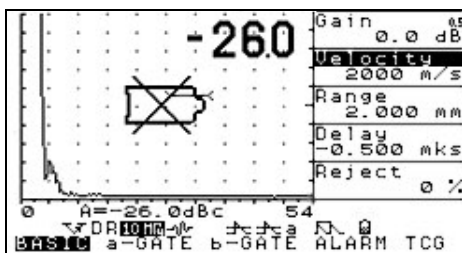

The UD2V-P45 automatically shuts off through two minutes. Settings are saved and restored when the instrument is turned on again.

NOTE: The UD2V-P45 can be operated on AC power with the AC/DC power adapter. This adapter is connected to the instrument through the Power Adapter Port shown in Figure 1-1.











1.2 Powering On and Off the Instrument

Press and hold  for three seconds to power the instrument on and off.





1.3 Keypad Features

The UD2V-P45 is designed to give the user quick access to all of the instrument's functions.

To access any function:

- Press one of keys   to select a menu. The submenus across the right of the display will be immediately replaced with the submenus contained in the selected menu.
- Press a   to move through submenu
- Press  to select desired function.
- Press   to change the function value
- Press  to exit from value changing mode or press one of keys   to select another menu.

You'll also find these keys and knobs on the instrument (figure 1-2):

-  - Freeze Key freezes the A-Scan display
-  - Zoom-in the signal in a-gate into full size of A-Scan display
-  - Copy Key, performs a data-storage
-  - Enter to additional menu (if no one function is selected) or service button.
-  - Power key turns instrument on and off

1.4 UD2V-P45 Menus and Functions

The UD2V-P45 menu system allows the operator to select adjust various features and instrument settings. It includes:

Main Menu - Several menus used to configure and calibrate the instrument prior to test. Also used to select pulser and receiver characteristics, position gates, set alarms, specify operating mode and screen appearance, adjust the A-Scan display, and control other significant measurement features.

Additional Menu - Allows the operator to make special adjustments like a pulser repetition frequency, change preselected speed and range values, etc.

Note: Figures 1-3 show the instrument's main menu structure. The information provided in the following manual section explains what each function does and shows how to access the function through the menu system.

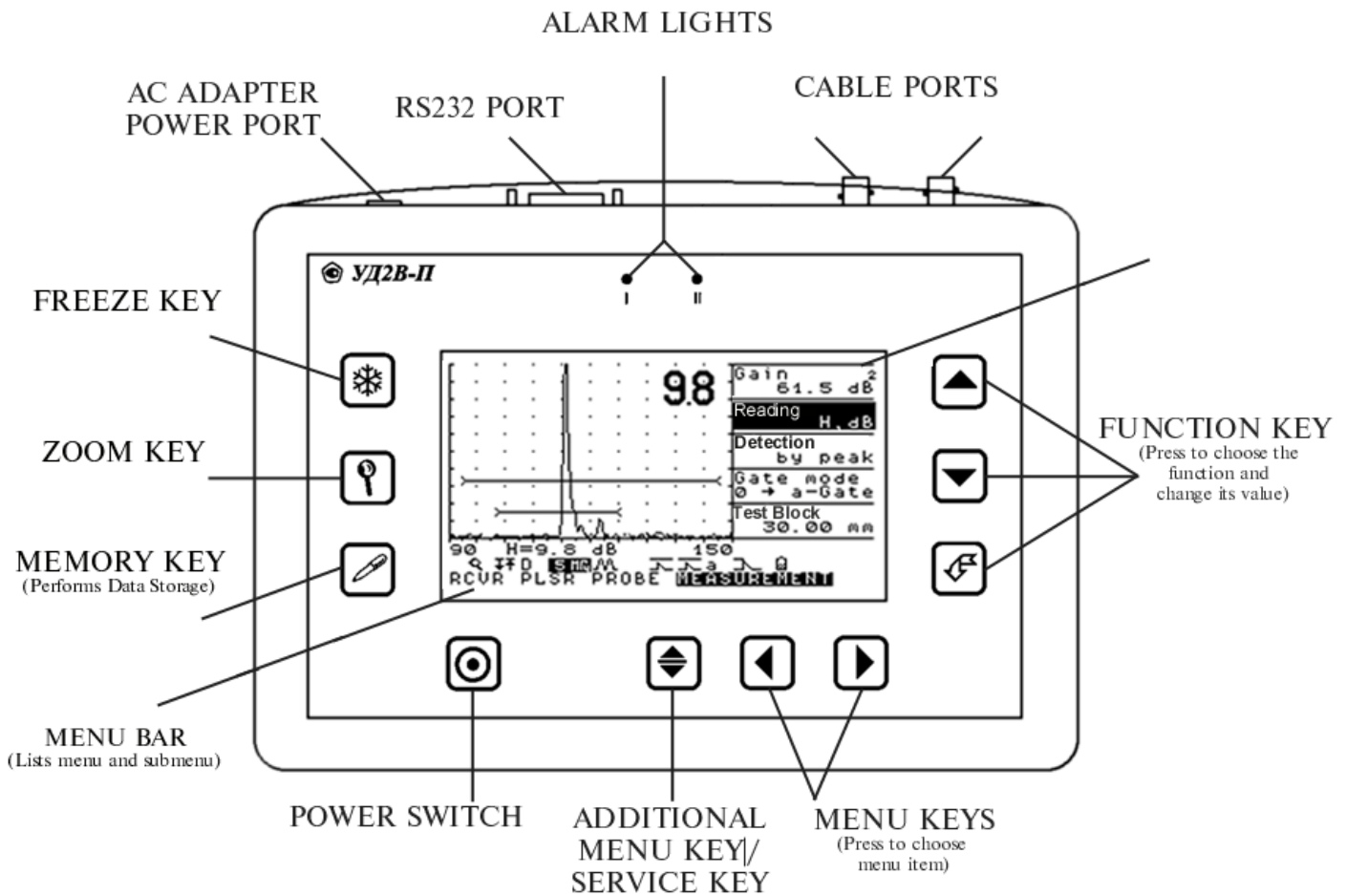

FIGURE 1-2—Some of the keypad functions are shown here.

1.4.1 Main Menu System

The UD2V-P45 Main Menu System consists of several submenus, and functions.

Then no one function is selected:

- To move through menu items use buttons
- To move through submenu items (functions) use buttons
- To select function press
- To enter in additional menu press

Then function is selected:



- To change function value use buttons
- To access additional function values press
- To deselect function press
- To move to another menu items use

Note: GAIN function is present i all submenus. To change a GAN step press then function is active. Steps may set : 0,5 dB; 1 dB; 2 dB; 6 dB.

Main Menu	Functions			
BASIC	Velocity	Range	Delay	Reject
a-GATE	a- Thresh	a- Start	a- Width	a- Logic
b-GATE	b-Thresh	b- Start	b- Width	b- Logic
ALARMS	Mode	Horn	Led	
TCG	Point	Position	TCG Gain	Active
RCVR	Freq	Analog Flt	Digit Flt	Rectify
PLSR	Damping	IP Width	PRF Value	
PROBE	Dual Mode	Damping	Angle	Delay
MEASUREMENT	Reading	Detection	Gate Mode	Test Block
DISPLAY	Contrast	Brightness	A-Magnify	TCG Curve
RESULTS	File	Save Result	Review File	Clear File
SETTINGS	Load Setting	Save Setting	Load Work Setting	

Figure 1-3 These functions are accessed through the Main Menu

MAIN MENU:**BASIC submenu:**

- **VELOCITY** – allows the user to input a velocity of the sound. Pressing  button then the function is active let to choose one of the four preselected values.
- **RANGE** - Adjusts the range of the display screen from 3MM to 3000MM (in steel). Pressing  button then the function is active choose one of the four preselected values.
- **DELAY** - —Shifts the A-Scan viewing window to the left or right.
- **REJECT** - Determines what percentage of the A-Scan height is displayed at 0% full screen height.

A-GATE submenu:

- **A-THRESH** - Sets the height of the a- gate
- **A-START** - Sets the beginning position of the a- gate on the A-scan
- **A-WIDTH** - Sets the width of the a-gate on the A-Scan
- **A-LOGIC** - Determines whether the gate alarm is triggered when a signal crosses the gate or does not cross the gate

B-GATE submenu:

- **B-THRESHOLD** - Sets the height of the b- gate
- **B-START** - Sets the beginning position of the b- gate on the A-scan
- **B-WIDTH** - Sets the width of the b-gate on the A-Scan
- **B-LOGIC** - Determines whether the gate alarm is triggered when a signal crosses the gate or does not cross the gate

ALARMS submenu:

- **MODE** - Determines whether the alarm is triggered when a signal is only in a-gate, only in b-gate, both in a- and b-gate, though in one of the a- or b –gate or by DAC.
- **HORN** - Enables the audible warning alarm (horn)
- **LED** - Enables the visible warning alarm

TCG (Time Corrected Gain) submenu:

- **POINT** – Up to 10 reference points may be recorded
- **POSITION** – Change position value for each point
- **GAIN** – Change gain value for each point
- **ACTIVE** – Turning on and off TCG Mode

RECIEVER submenu:

- **FREQ** – Selects the bandwidth of the instrument.
- **ANALOG FLT** – On and Off analog filter
- **DIGIT FLT** – Change digital filter
- **RECTIFY** – Selects the rectification mode which effects how the A-Scan appears on the display

PULSER submenu:

- **DAMPING** – On and off pulser damping (50 Ohm)
- **IP WIDTH** – Changes the initial pulse width to match the installed probe
- **PRF VALUE** – Displays actual Pulse Repetition Frequency

PROBE submenu:

- **DUAL MODE** – Identifies whether one or two single-element probes, or a dual, is installed
- **DAMPING** – On and off probe damping (50 Ohm)
- **ANGLE** –Input the angle of a connected angle beam probe
- **DELAY** – Allows input time delay caused by sound-wave travel through a probe’s wearplate, membrane, delay line, or wedge

MEASURE submenu:

- **READING** - Selects the measurement displayed in Reading Box
- **DETECTION** – Selects whether an A-Scan echo’s flank, or peak is evaluated by the gate
- **GATE MODE** – Selects time calculation mode: from IP to a-gate, or between a- and b-gates.
- **BLOCK**- Allows to input Calibration Block Size for velocity calculating

DISPLAY submenu:

- **CONTRAST** - Allows to change the display’s contrast from 0 to 100%
- **BRIGHTNESS** – Allows to change the display’s brightness from 0 to 100%
- **A-GATE MAGNIFY** – Allows user to magnify a-gate to full screen size
- **TCG CURVE**- Select which curve displays – TCG, DAC or no one.

RESULTS submenu:

- **FILE** - Selects one of 10 data files
- **SAVE RESULT** – Saves the measurement value in selected file
- **REVIEW FILE**– Allows user to review selected file
- **CLEAN FILE**- Deletes the selected file

SETTINGS submenu:



- **LOAD SETTING** - Loads the settings
- **SAVE SETTING** – Saves the settings
- **LOAD WORK SETTING**– Load working setting (setting which loading then instrument turning on)

1.4.2 Additional Menu System

Additional Menu consist of those functions, which frequent use are not necessary.

To enter in additional menu press  then no one function in submenus is selected.

To use the additional menu:

Press   - to navigate through menu and to change function value, then function is selected.

Press  - to select/deselect function

Press  - to exit from additional menu















FUNCTIONS	FUNCTION DESCRIPTION
TEST MODE	ECHO / TX-RX Select the control technique – echo method or using two probes on opposite sides of test piece
FILLING	ON / OFF Turns on and off A-signal filling (except RF rectification)
GRID	ON / OFF Turns Coordinate Grid on and off
DIGITS	ON / OFF Displas readings by big numbers on the screen.
PRF	40 Hz / Max Select Pulser Repetition Frequency : maximum or 40 Hz
Reference A, dBc	Input reference amplitude value – for "A, dBc" measurement mode.
DAC amplitude	Input DAC position in % of the screen height
Velocity 1	Input 1-st preselected velocity value
Velocity 2	Input 2-nd preselected velocity value
Velocity 3	Input 3-d preselected velocity value
Velocity 4	Input 4-th preselected velocity value
Range 1	Input 1-st preselected range value.
Range 2	Input 2-nd preselected range value
Range 3	Input 3-d preselected range value
Range 4	Input 4-th preselected range value
Basic Frequency	Special function for metrological checkup. Send impulses to pulser cable port with 20 KHz frequency

1.5 Display Screen Features

The UD2V-P45 displays are designed to be easy to interpret. Display includes active A-scan, main menu system, numerical measurement results and special graphical icons.

Definition of Display Icons

There are several graphical features (icons) which appear in the display screen's icon bar for various reasons.

*	- Freeze mode has been activated: by pressing  button or loading A-scan from settings;
	-A-gate magnify mode has been turned on
	Pulsar set for one single element probe
	- Pulsar set for dual element probe
D	- pulser damping has been turned on
R	- probe damping has been turned on
10 MHz	- central frequency 5 MHz , 2.5MHz or 1.25MHz . If invert symbol is appear 5 MHz - all filters turned off
<i>Rectification</i>	
	- full wave;
	- positive wave;
	- negative wave;
	- RF signal;
	- TCG mode is turned on;
	- <i>gate logic</i> (alarm is triggered when a signal crosses the gate). A-gate logic symbol displays left.
	- <i>gate logic</i> (alarm is triggered when a signal does not cross the gate). B-gate logic symbol displays right.
<i>Alarm logic</i>	
a b	- then signal in both a & b gates;
a	- then signal only in a-gate;
b	- then signal only in b-gate
a b	- then signal though in one of the a or b –gate;
DAC - DAC mode;	
<i>Time measurement mode</i>	
	- from IP to A-scan echo flank;
	- from A-scan echo flank to B-scan echo flank ;
	- from IP to A-scan echo peak;
	- from A-scan echo peak to B-scan echo peak

1.6 Features of the UD2V-P45

- LCD Display 240 x 128 pixels with “Analog Look” echo dynamics
- Weighs only 2 kg including standard C-size batteries for convenient use anywhere
- Two independent flaw gates with real-time TTL Outputs to handle a wide range of applications
- 500KHz to 15 MHz capability with four selectable frequency ranges to match probe for optimum performance
- 40 Hz PRF (pulse repetition frequency) with 3000m range in steel eliminates “ghost echoes” making it ideal for lengthy acoustically clean material testing
- Up to 800 Hz PRF for testing productivity and using in automatic control applications
- TCG/ DAC feature
- Eight hours of use on standard C-size 3.5 Ahr NiMH. (AC adapter for bench-top use)
- Three selectable damping settings: 50 Ohm pulser damping, 50 Ohm receiver damping and 25 Ohm (only in single mode)
- Trig functions for automatically determine depth, surface distance, sound path to flaws
- RF rectification for phase inversion and thin measurement application
- 3 mm minimum range (in steel) for thin measurement applications
- dB step function with four gain steps
- Thickness data logger for 1000 results storage
- Memory for 64 settings with A-scan
- Upgrade CD is provided with each instrument to easily upgrade the Operating Software via Kropus’s website without returning the instrument to add features and capabilities without downtime
- Four Analog and 12 digital filters for signal-to-noise ratio improve

2. Set Up and Calibration of the UD2V-P45



This chapter explains how to prepare your instrument for use. In this chapter, you'll learn how to :

- Set up the instrument's display and basic operating features
- Install a probe and configure the Pulser/Receiver to match the probe type
- Adjusting the A-Scan display screen's appearance
- Calibrate the instrument

Most sections in this chapter describe steps that will be followed by every user of a new instrument. For this reason, we suggest that you proceed through each section in this chapter while configuring your instrument for the first time.

2.1 Initial Instrument Setup





This part of the manual describes how to configure the UD2V-P45 instrument's display and operating features. Follow these procedures to turn on the UD2V-V45 and make initial adjustments to the instrument control settings. Because the instrument saves the control settings when it's turned off and restores them when it's turned on, you won't have to repeat these adjustments unless a change is required.

Turn on the UD2V-P45 by pressing  for at least three seconds. The Main Menu system will appear on the screen. Navigate through menu by pressing   buttons.



2.1.1 Display Appearance

Use the procedures in this section to adjust display appearance. The adjustments will require access to the DISPLAY submenu, which is accessed from the Main Menu and also GRID and FILLING function, which are accessed from the Additional Menu.

Setting the Display Contrast (DISPLAY-CONTRAST)

Step 1. Find the DISPLAY submenu by pressing   buttons and CONTRAST function in this submenu by pressing   buttons.

Step 2. Activate the CONTRAST function by pressing  on it. The function appearance will be inverse.



Step 3. Change contrast value by pressing   buttons. Settings range from 0 to 100 %.

Step 4. To De-activate function press  button

Step 5. The display contrast will remain at the level last displayed

Setting the Display Brightness (DISPLAY-BRIGHTNESS)

Step 1. Activate the Brightness function by pressing 



Step 2. Change brightness value by pressing   buttons. Settings range from 0 to 100 %.

Step 3. To De-activate function press  button

Step 4. The display brightness will remain at the level last displayed

Setting the Display Grid (Additional Menu –GRID)

Step 1. Then no one function is active, press  button

Step 2. Navigate through menu by pressing   buttons







Step 3. Activate GRID function by pressing  button

Step 4. Change function value. Available values are YES or NO.

Step 5. De-activate GRID function by pressing  button

Step 6. Exit from Additional Menu by pressing  button

Setting the A-scan Style (Additional Menu – FILLING)

- Step 1. Then no one function is active, press  button
- Step 2. Navigate through menu be pressing pressing   buttons
- Step 3. Activate FILLING function be pressing  button
- Step 4. Change function value. Available values are YES or NO.
- Step 5. De-activate FILLING function by pressing  button
- Step 6. Exit from Additional Menu be pressing  button

2.2 Installing a probe

2.2.1 Connecting a probe





Very important that the instrument is properly configured to work with the installed probe. The UD2V-P45 operate with one or two single-element probes or with a dual-element probe.

To install a single-element probe, connect the probe cable to either of the two ports on the top of the instrument. When two probes, or a dual-element probe is connected to the instrument, the “RECEIVE” probe connector should be installed in the left port and the “TRANSMIT” probe connector in the right port.

2.2.2 Configuring the Instrument to Match the Probe Type

Some instrument settings are directly dependent on the type of probe installed. These settings must be adjusted any time a probe of a different type is installed.

Selecting Probe Type (PROBE-DUAL MODE)

- Step 1. Activate the DUAL MODE function by pressing  button
- Step 2. Change probe type according to installed probe.
ON – for dual probe or two single probes ( will appear on the display), **OFF** – for one single probe ( will appear on the display).
- Step 3. De-Activate the DUAL MODE function by pressing  button

Specifying the Probe Frequency (RCVR-FREQ)

- Step 1. Activate the FREQ function by pressing  button

Step 2. Select the central frequency to match probe **1.25MHz**, **2.5MHz**, **5 MHz** or **10 MHz**. The more frequency selected the more measurement accuracy and lesser testing productivity will be achieved.

With **10 MHz** central frequency instrument provides broadband mode from 0,5MHz to 15 MHz (-6dB).

Specifying the IP Width (PLSR-IP WIDTH)

- Step 1. Activate the IP WIDTH function by pressing  button
- Step 2. Select the IP Width in range from 50 ns to 500 ns according to probe frequency. Normally selecting IP Width equal to 1/2 of frequency period.
Example 1: Probe frequency F=5 Mhz. Period is equal 1/F = 200 ns. IP Width for optimal probe excitation is equal 100 ns.

In common case:

1,25 Mhz IP Width=400 ns
2,5 Mhz IP Width=200 ns
5 MHz IP Width=100 ns
10 MHz IP Width=50 ns

Actual necessary IP Width may differ from this calculations and operator can change nominal IP Width to get maximum amplitude and optimal echo width.



Modifying Signal Ratio to Noise by changing the damping Level

There are four damping levels provided by the instrument:

- no damping (600 Ohm)
- Pulser Damping (50 Ohm)
- Probe (Receiver) Damping (50 Ohm)
- Both Pulser and Receiver damping (25 Ohm in Single mode)

Pulser Damping (PLSR-DAMPING)



Step 1. Activate the DAMPING function in PULSER submenu by pressing  button

Step 2. Change Pulser damping by pressing   buttons. Available values are **OFF** or **50 Ohm**

Step 3. De-activate DAMPING function by pressing  button

Probe (Receiver) Damping (PROBE-DAMPING)

Step 1. Activate the DAMPING function in PROBE submenu by pressing  button

Step 2. Change Pulser damping by pressing   buttons. Available values are **OFF** or **50 Ohm**.

Step 3. De-activate DAMPING function by pressing  button

Note: All Kropus's probes have built-in inductance elements for matching instrument cable ports. If you want to use other manufacturer's probe be sure built-in inductance elements is present or use external inductance elements.

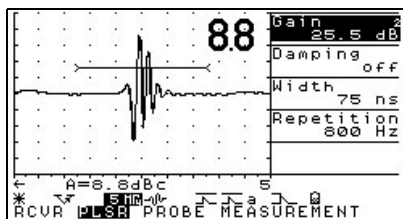

a)

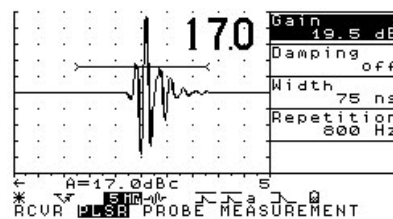

b)

Fig. ____ Single Element Probe 5 Mhz. a) IP Width = 75 ns, without inductance element
b) IP Width = 75 ns, with inductance element 1,1 μH

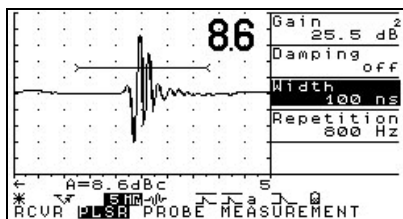

a)

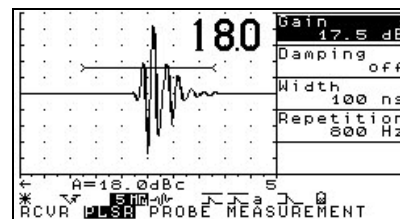

b)

Fig. ____ Single Element Probe 5 Mhz. a) IP Width = 100 ns, without inductance element
b) IP Width = 100 ns, with inductance element 1,1 μH

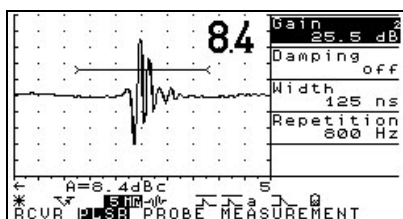

a)

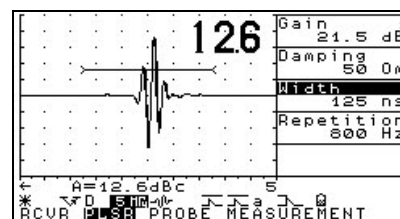



b)

Fig. ____ Single Element Probe 5 Mhz. a) IP Width = 125 ns, without inductance element
b) IP Width = 125 ns, with inductance element 1,1 μH and 50 Ω Pulser Damping

Note: From upper figures we see what maximum amplitude settings is IP Width = 100 ns, with inductance element 1,1 μH; minimum echo width settings is IP Width = 125 ns, with inductance element 1,1 μH and pulser damping. Digits on display matching A, dBc measurement towards input signal with 1 V amplitude. Horizontal grid step is equal 0,5μsec per point.

**Specifying the Control Mode
(Additional Menu-TEST MODE)**

Step 1. Enter to Additional Menu by pressing  button, then no one function is active.

Step 2. Navigate through menu be pressing pressing   buttons

Step 3. Activate CONTROL MODE function be pressing  button

Step 4. Change function value. Available values are ECHO or TX-RX. If connected one single element probe or dual element probe set function value to ECHO. If installed two single element probes (one for transmit and one for receive to opposite testing piece sides) set function value to TX-RX.

Note: This function value causes influence only into time measurement results. In ECHO mode time measurement value will be divided on 2.

Step 5. De-activate TEST MODE function by pressing  button

Step 6. Exit from Additional Menu be pressing  button



Modifying Signal to Noise Ration by application of filters.



UD2V-P45 has two types of filters : analogical filter for each central frequency (1,25 MHz; 2,5 MHz; 5MHz and 10 MHz) and four digital narrow band filters for each central frequency (except of 10 MHz)

**Turning on the analogical filter
(RCVR-ANALOG FLT)**

Step 1. Set up central frequency (RCVR-FREQ) which according the probe frequency.

Step 2. Activate **ANALOG FLT** function in RCVR submenu by pressing  button



Step 3. Turns on or off analogical filter by pressing   buttons.

Note: If one of analogical or digital filter will be active the frequency symbol  will be invert - 

**Turning on digital filters
(RCVR-DIGIT FLT)**

Step 1. Set up central frequency (RCVR-FREQ) which according the probe frequency.

Step 2. Activate **DIGIT FLT** function in RCVR submenu by pressing  button





Step 3. Select digital filter by pressing   buttons.

Next digital filters are available:

Digital Filter	5 MHz	2,5 MHz	1,25 MHz
Broadband	0,5 .. 8	0,5 .. 4	0,5 .. 2
Wide	3,1 .. 6,9	1,55 .. 3,45	0,77 .. 1,73
Medium	3,7 .. 6,3	1,85 .. 3,15	0,92 .. 1,58
Narrow	4,2 .. 5,8	2,10 .. 2,90	1,05 .. 1,45

2.3 Adjusting the A-scan

2.3.1 Setting the A-Scan Range (BASIC-RANGE)

Step 1. Activate RANGE function by pressing  button
 Step 2. Select one of four preselected range value by pressing  button or adjust range manually by pressing   buttons. Overall range can changes from 1 to 1000 μ sec or from 3 mm to 2975 mm with step \approx 1mm. (in steel)

Note: The more frequency set up in RECIEVER-FREQUENCY box the more accuracy may be achieved then range changing.



Step 3. The display's horizontal range will remain as set.

Note: The overall range value depends from RECIEVER-FREQUENCY value.

Frequency	10 MHz	5 MHz	2,5 MHz	1,25 MHz
Minimum range	1 μ s	2 μ s	3 μ s	4 μ s
Maximum range	250 μ s	500 μ s	1000 μ s	1000 μ s

2.3.2 Setting the Display Delay (BASIC-DELAY)







The display delay function shifts the displayed A-Scan to the left or right. This function is used to set the UD2V-P45 viewing window. To set the display delay:

Step 1. Activate DELAY function be pressing  button
 Step 2. Adjust delay value pressing   buttons. Overall range can changes from -0,5 to 996 μ sec.

2.3.3 Selecting the Pulsar Repetition Frequency Mode (Additional Menu – PRF)

The Pulsar fires at a frequency which can either be set automatically or manually. Maximum PFR is 800 Hz. You'll note what actual PRF value always available by activate **PFR VALUE** function in PULSER submenu.

To select the PRF mode

Step 1. Enter to Additional Menu by pressing  button, then no one function is active.
 Step 2. Navigate through menu be pressing   buttons
 Step 3. Activate PRF function be pressing  button
 Step 4. Change function value. Available values are 40 Hz or MAXIMUM. In MAXIMUM mode maximum available PFR for selected range and receiver central frequency will be achieved.
 Step 5. Deactivate PRF function be pressing  button
 Step 6. Exit from Additional Menu by pressing  button

2.3.4 Selecting a Rectification Mode (RCVR-RECTIFY)

Rectification effects the orientation of the A-scan on the display screen. The A-scan represents the sound pulse (echo) that's returned from the material being tested to the instrument. The series of echoes looks like the Radio Frequency (RF) signal. Note that the RF signal has a negative component below the axis, and a positive component above the axis. In RF mode, the A-gate and B-gate can be positioned either above or below the axis, to be triggered by a positive-heading echo or a negative-heading echo.

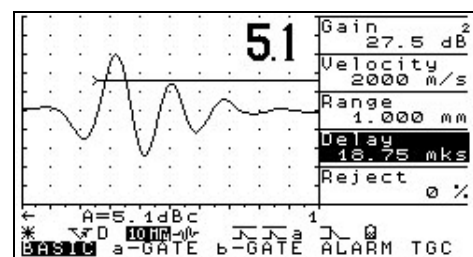

Fig. Radio Frequency signal

Positive Half Rectification means that only the upper (positive) half of the RF signal is displayed

Negative Half Rectification means that only the bottom (negative) half of the RF signal is displayed.

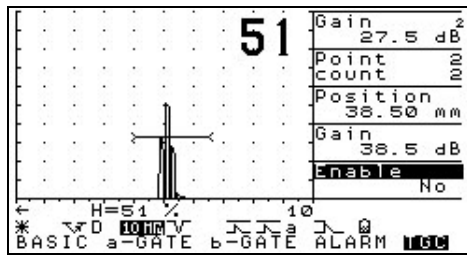

Fig. Negative $\frac{1}{2}$ wave rectification

Note: even though it's the negative half of the RF signal, it's displayed in the same orientation as a positive component. This is only to simplify viewing. The signal displayed in the view identified as Negative Reactance is the negative component of the RF signal.

Full-Wave Rectification combines the positive and negative rectified signals together, and displays both of them in a positive orientation.

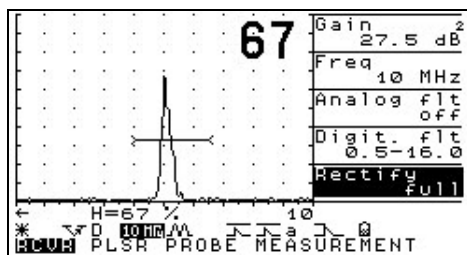

Fig. Full wave rectification

Use the following procedure to select a rectification mode

Step 1. Activate RECTIFY function in RCVR

submenu by pressing button

Step 2. Change rectification mode by pressing

buttons.

- **NEG**—Shows the negative component of the RF signal but displays it in a positive orientation
- **POS**—Shows the positive component of the RF
- **FULLWAVE**—Shows the positive and negative halves of the RF wave, but both are oriented in the positive direction
- **RF**—Shows the echo with no rectification

2.3.5 Setting the A-Scan REJECT Level (BASIC-REJECT)

A portion of the A-Scan can be omitted from the display screen. To omit a portion of the A-Scan, you must define the percentage of full-screen height you wish to omit. To set a reject percentage

Step 1. Activate the REJECT function (located in the BASIC submenu) by pressing button

Step 2. To change the amount of A-Scan you wish to omit from the display screen (as a percentage of screen height) press buttons. You may omit A-Scans up to 80% of the screen height.

3. Configuring Your Instrument for Measurement

This chapter explains how to configure your instrument's flaw detection and thickness measurement capabilities.

In this chapter, you'll learn how

- Adjust the A and B-Gates and alarms
- Choose a GATE-DETECTION MODE (peak or flank)
- Specify the action taken by the A-GATE MAGNIFY MODE
- Setting the Amplitude measurement units
- Specify the action taken by the FREEZE MODE
- Configure the instrument for use of ANGLE BEAM PROBES

3.1 Configuring the A and B-Gates

Setting the position and characteristics of the A and B-Gates is the first step to configuring the UD2V-P45 for flaw detecting or material-thickness measurement.

3.1.1 Positioning Gates

Use the following procedures to set the vertical and horizontal position of the A and B-Gates. Remember that gate position has the following effects on instrument performance:



- A-Scan echoes on the right side of the display screen represent features that occur at a greater depth from the test-material surface than those on the left of the display screen. Therefore, moving a gate to the right means that the gate is evaluating a deeper portion of the test material
- A wider gate will simply span the equivalent of more test-material depth
- Increasing the vertical height (called threshold) of a gate means that only reflected signals of sufficiently large amplitude will cross the gate

Setting a Gate's Starting Point (A-GATE - A-START) or (B-GATE - B-START)

Step1. Activate A-START (B-START) function by pressing  button

Step 2. Change gate start position by pressing  buttons.

You'll note that A-START (B-START) function has both coarse and fine adjustment modes. Coarse and fine modes are selected by pressing  button then function is active.



- When "a-start" or "b-start" appears in all small letters, pressing  buttons will change the value by smaller amounts.
- When "a-START" or "b-START" appears in capital letters, pressing  buttons will produce large changes in gate start value.

Adjusting a Gate's Width (A-GATE - A-WIDTH) or (B-GATE - B-WIDTH)

Step1. Activate A-WIDTH (B-WIDTH) function by pressing  button

Step 2. Change gate width by pressing  buttons.

You'll note that A-WIDTH (B-WIDTH) function has both coarse and fine adjustment modes. Coarse and fine modes are selected by pressing  button then function is active.



- When "a-width" or "b-width" appears in all small letters, pressing  buttons will change the value by smaller amounts.
- When "a-WIDTH" or "b-WIDTH" appears in all capital letters, pressing  buttons will produce large changes in gate width value.

Note: The gate start and gate width changing accuracy depends of selected receiver frequency

Frequency	10 MHz	5 MHz	2,5 MHz	1,25 MHz
Min. step of gates position and width changing	0,025 μ s	0,05 μ s	0,1 μ s	0,2 μ s

Setting a Gate's Threshold (Vertical Position) (A-GATE – A-THRES) or (B-GATE – B-THRES)

Step1. Activate A-THRESH (B-THRESH) function by pressing  button



Step 2. Change gate threshold by pressing   buttons. Available values are from 0 to 95% in Full Wave, Positive and Negative wave modes and from –95% to 95% in RF mode.

3.1.2 Selecting the Gate Detection Method

A-Scan signals crossing the A or B-Gate are evaluated for the purposes of flaw detection and material-thickness evaluation. When the signal crosses the A or B-Gate, either the gate-crossing point (flank) of the signal, or the maximum point (peak) of the signal (in a-gate) is used for evaluation purposes. The DETECTION function allows the user to specify which A-Scan feature (FLANK or PEAK) is used to evaluate the signal in a-gate.

Setting the A-Scan Signal-Detection Method (MEASURE-DETECTION)

Step1. Activate DETECTION function in MEASURE submenu by pressing  button

Step 2. Change detection mode position by pressing   buttons. Available values are PEAK or FLANK



3.1.3 Setting Gate Alarms

An alarm can be set for each of the two gates. When a gate alarm is activated, one or more of the following will occur:

- An alarm indication light on the front of the instrument will illuminate
- An audible alarm (HORN) will sound
- A TTL alarm signal will be output

Turning On/Off the indicators illumination (ALARMS-LED)



Step1. Activate LED function in ALARMS submenu by pressing  button

Step 2. Set led function value by pressing   buttons. Available values are YES or NO

Turning On/Off the audible signal (ALARMS-HORN)

When any gate's alarm is triggered, an audible horn will sound. Use the following procedure to turn this horn off or on:



Step1. Activate HORN function in ALARMS submenu by pressing  button

Step 2. Set horn function value by pressing   buttons. Available value are YES or NO



Defining Gate-Alarm Logic

Each gate's alarm can be triggered under one of two circumstances. Gate alarms can be set to trigger when an A-Scan echo crosses the gate or when **no** echo crosses the gate. Use the following procedure to specify GATE LOGIC settings:

Step 1. Activate A- LOGIC (B-LOGIC) function by pressing  button

Step 2. Change gate logic by pressing   buttons.



Available values are

-  - alarms, then the echo cross the gate
-  - alarms, then the echo not cross the gate
- OFF – gate alarms turned off

3.1.4 Setting the Horn mode (ALARMS-MODE)

This feature sets then the audible signal will triggered

Step1. Activate MODE function in ALARMS submenu by pressing  button

Step 2. Set function value by pressing   buttons. Available value are



- **A-GATE** – then alarms only in a-gate
- **B-GATE** - then alarms only in b-gate
- **A & B-GATE** – then alarms in both a and b-gates
- **A or B – GATE** – then alarms though in one of the gates
- **BY DAC**– then echo crosses the DAC Curve

3.1.5 Settings the Displaying Measure (MEASURE-READING)

The instrument can calculate six type of measures, but only one of them can be displayed at same time.

To set measure will be displayed in reading box

Step 1. Activate READING function by pressing  button

Step 2. Change measure type by pressing   buttons.

Available measures are

- S, mm – sound path.

Note: If PROBE-ANGLE function value more than zero instrument calculates both X and Y measures for angle beam probe control, but in reading box presents only S-symbol with Y-value. To displaying both X and Y - set DIGITS function value (in Additional Menu) to YES. Then big numbers will appear in the top-right corner of the screen. The top number is the Y value, the bottom X value.

- V, m/s – velocity of sound.



Note: For calculation velocity of sound the reference block thickness must be set by MEASURE-BLOCK function.

- H, % -amplitude in % of screen height
- H, dB –displays amplitude readings as a dB difference between the echo’s peak and the a-gate threshold
- H, % - average amplitude value in a-gate
- A, dbc - displays readings as a dB difference between the echo in the a-gate and the reference echo.

3.1.6 Settings the Measurement Mode (MEASURE-GATE MODE)

This feature define how the time will be measured: from IP to A-gate, or between a-gate and b-gate

Step1. Activate GATE MODE function in MEASURE submenu by pressing  button



Step 2.Change the mode by pressing   buttons. Available modes are “0 → A-GATE” and “A → B-GATE”

3.2 Using Angle Beam Probes

When connecting an angle beam probe to the instrument, adjustments must be made for probe characteristics as well as test-piece geometry.

Setting angle for angle beam probe (PROBE-ANGLE)

Step1. Activate ANGLE function in PROBE submenu by pressing  button

Step 2.Change angle by pressing   buttons.

Available values are from 0° to 85 °

Note: Then angle is set, the S value in bottom-right corner no more means sound path value. It will be equal to Y measure (depth of flaws).

3.3 Saving the Instrument Configuration In Data Set



Instrument settings can be stored as Data Sets. When a stored data set is later recalled, all active functional settings are replaced with those settings contained in the data set, and the stored A-Scan is displayed and frozen on the display screen. Once a data set is recalled, the newly active functional settings may be modified. However, once a data set is stored, functional settings within that data set may not be permanently modified. Anytime that data set is recalled, the functional settings will be returned to their initially stored values.

Saving settings in Data Set (SETTINGS-SAVE SETTING)

Step1. Activate SAVE SETTING function in SETTINGS submenu by pressing  button.

Note: Then the SAVE SETTING function is active the list consist of 64 data set names appears. The previously saved data set has symbol ==, the empty data set has symbol.

Step 2. Use   buttons to select data set.



Step 3. Use  button to save settings in data set or use  button to enter RENAME DATA SET MODE (see **Renaming Data Set**).

Recalling settings from Data Set (SETTINGS-LOAD SETTING)

Step 1. Activate LOAD SETTING function in SETTINGS submenu by pressing  button.

Note: Then the LOAD SETTING function is active the list consist of 64 data set names appears. The previously saved data set has symbol ==, the empty data set has symbol.

Step 2. Use   buttons to select data set.

Step 3. Use  button to load settings from data set or use  button to enter RENAME DATA SET MODE (see **Renaming Data Set**).

Renaming Data Set

Then LOAD SETTING or SAVE SETTING function is active you can change Data Set name from keypad.

Step 1. Use   buttons to select data set.

Step 2. Use  button to enter RENAME DATA SET MODE. **The cursor on first symbol of Data Set name will blink.**



Step 3. Use   buttons to change symbol in Data Set name.

Note: Only English alphabetic capital characters, digits and some special symbols are available in this mode. By PC Soft Package employment any ASCII characters are available.

Step 4. Use   buttons select next symbol in Data Set name

Note: Overall Data Set name length is 28 symbols max.

Step 5. Use  button to exit from RENAME DATA SET MODE. **The cursor on first symbol of Data Set name will stop blink**



Step 6. Use  button to load/save settings (depends on function) or  to exit in Main Menu.

4. Using the Instrument during test operations

4.1 Setting the Gain



Instrument gain, which increases and decreases the height of a displayed A-Scan, is adjusted with the Gain Function. The instrument's gain can be adjusted while in any Main Menu location.

4.1.1 Changing the Gain-Adjustment Increment (dB STEP)

When adjusting the A-Scan gain, each pressing of the   buttons, then the gain function is active, increases or decreases the gain level by a dB increment equal to the dB STEP. Several values can be specified for dB STEP. To select one of the existing dB STEP values:

Step 1. Activate Gain Function by pressing  button.

Step 2. Press  button to select one of four existing dB steps. They are **0,5dB**; **1dB**; **2dB** and **6dB**.

Step 3. Once a dB STEP value has been selected, each pressing of the   buttons, will increase or decrease the instrument's gain by the dB STEP increment.



4.2 Using the dB Reference Feature

When **A, dBc** is activated, the amplitude of the echo in A-Gate will compare with the reference echo recorded in Additional Menu **A, dBc function**. This value means the gain at which the reference signal is 100% screen height.

Note: For properly compare echo in A-Gate will must be in 30-100 % of screen height.

To record reference echo

Step 1. Enter to Additional Menu by pressing  button, then no one function is active.

Step 2. Navigate through menu be pressing pressing   buttons

Step 3. Activate **REFERENCE A, dBc** function be pressing  button

Step 4. Change function value.

Step 5. De-activate **REFERENCE A, dBc** function by pressing  button



Step 6. Exit from Additional Menu be pressing  button

4.3 Saving the measurement results

Measurement results may be stored in data logger files. Totally may be stored 1000 results (10 data logger files with 100 results in each file). To save displayed result press  button or select from RESULTS submenu SAVE RESULT function.

To select one of 10 data logger files:

Step1. Activate FILE function in RESULTS submenu.

Step2. Change file by pressing   buttons

To review contents of data logger file: activate REVIEW function in RESULTS submenu.

To clear content of data logger file: activate CLEAR FILE function in RESULTS submenu

4.4 Magnifying the Contents of the A-Gate

Whenever an A-Scan is active press  button or activate A-MAGNIFY function in DISPLAY menu. MAGNIFY feature enlarges the displayed portion of the A-Scan contained in a a-gate. The width of the magnified gate determines the level of magnification. This is because the display is magnified until the gate width equals 100% full-screen width.

5. DAC/TCG Feature

The UD2V-P45 is supplied with Time Corrected Gain (TCG) and Distance Amplitude Correction (DAC) functions. Both the DAC and TCG functions operate based on a set of user-recorded data points.

The TCG function displays reflectors of equal size at equal A-Scan amplitudes, regardless of the reflector's depth in the test material. It accomplishes by adjusting the gain at different locations in the A-scan display, corresponding to different material depths, to compensate for signal loss (or variation) due to attenuation, beam spread, or other factors.

When TCG is activated  icon appears in the status bar.

The DAC function displays all echoes at their true amplitude (without depth compensation). However, when operating in DAC mode, Distance Amplitude Correction curve are superimposed on the A-Scan display.

5.1 Using TCG

When the TCG function is in use, echoes from equally sized reflectors appear as the same height on the A-Scan display. Before using the TCG function do the following:

Step 1. The instrument/probe combination has been calibrated and all instrument settings (PULSER, RECEIVER, etc.) have been made. Changing these settings after the TCG reference points are input will effect the accuracy of measurement.

Step 2: TCG reference points (up to 10) must be recorded. This process allows the UD2V-P45 to calculate and compensate for the effect on material depth on reflector-echo height. The dynamic range of the TCG function is up to 90 dB (depends of gain value). Maximum curve slope is 12 dB per microsecond.

5.1.1 Recording the TCG Reference Points



TCG reference points are recorded in exactly the same manner as those points used to create the DAC curve. Points are typically taken from a standard with equally sized reflectors (holes) located at various material depths. The primary echo from each of these points (for up to a total of 10 echoes) are recorded.

When TCG is active, the instrument compensates for different material thickness by applying a varying gain level to echoes at material depths other than the baseline depth. Either one set of TCG reference points or one DAC curve can be stored at a time.

To program TCG reference points:

Step 1. Couple the probe to the first reference point and, using a-START and a-THRESH function in a-GATE submenu, adjust the a-Gate so that it is broken by the primary echo. If necessary, use the Gain function to adjust the gain so that the echo crosses the a-Gate and the highest peak in gate is at approximately 80% of full-screen height. The highest peak must not be higher than 100% full-screen height.

IMPORTANT NOTE: As reference point position will be accepted signal peak position

Step2. Access the TCG submenu and activate POINT function by pressing  button. While the Gate is lined up over the first reference echo record the first point by pressing  button. The "1" value will appear opposite "count" title in the bottom line of POINT function box.

Note that the largest echo crosses the A-Gate will be treated as the reference echo. The gain value at which this point is recorded becomes the "baseline" gain value.

Step 3: Continue to take additional reference points, following steps 1 and 2, up to a maximum of 10 points (note that at least two reference points are required).



Step 4: Note that stored TCG reference points can be edited as described in Section 5.3

NOTE: TCG reference points, curve, and status (ON/OFF, TCG OR DAC) will be stored with data set. When recalled, curve status will be the same as when it was stored. For example, if TCG is active when a data set is stored, it will be active when that data set is recalled.

5.1.2 Working with TCG



In TCG mode the instrument uses the recorded reference points to calculate an amount of gain correction required to display each echo from same-size reflectors at the same amplitude. The recorded reference point data is stored until replaced or edited. To use the stored reference points and operate in TCG mode:

Step 1: With the TCG submenu accessed, select the ACTIVE function by pressing  button.

Step2. Turning On or Off TCG by pressing   buttons.
( will appear if TCG is active)

To display recorded TCG or DAC curve:

Step 1. With the DISPLAY submenu accessed, select the TCG CURVE function by pressing  button.

Step2. Change function value by pressing by pressing   buttons. Available values are:
TCG – to display TCG curve
DAC – to display DAC curve
NO – to not display any curves

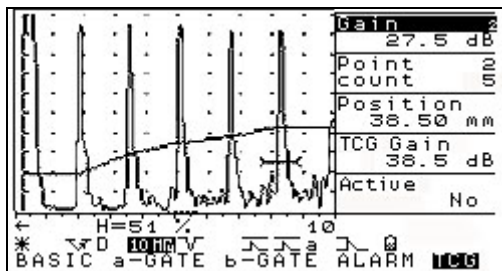

NOTE: The TCG CURVE graphically represents the level of gain applied at each of the user-input reference points. This compensating gain is represented by the height of the TCG curve while the material depth of each reference point is represented by its horizontal position on the display screen.

5.2 Using DAC

When displayed, the DAC curve visually represents a line of constant reflector peaks over a range of material depths.

NOTE: In DAC mode, the only deviation from traditional display and operation is the appearance of the DAC curve. All A-Scan echoes are displayed at their non-compensated height.

DAC curve can be based on up to 10 data points (material depths).

A DAC curve is programmed using a series of same-reflector echoes at various depths covering the range of depths to be inspected in the test material. Because near field and beam spread vary according to transducer size and frequency, and materials vary in attenuation and velocity, DAC must be programmed differently for different applications.



The dynamic range of the DAC function is 90 dB max. Maximum curve slope is 12 dB per microsecond.

5.2.1 Recording the DAC Curve

DAC Curve points are recorded in exactly the same manner as those points used to create the TCG reference. Points are typically taken from a standard with equally sized reflectors (holes) located at various material depths. The primary echo from each of these points (for up to a total of 10 echoes) are recorded. When DAC is active, the instrument displays a curve that represents echo peaks for constant reflectors at varying material depth. Either one DAC curve or one set of TCG reference points can be stored at a time. To program the DAC Curve :

Step 1. Couple the probe to the first reference point and, using a-START and a-THRESH function in a-GATE submenu, adjust the a-Gate so that it is broken by the primary echo. If necessary, use the Gain function to adjust the gain so that the echo crosses the a-Gate and the highest peak in gate is at approximately 80% of full-screen height. The highest peak must not be higher than 100% full-screen height.

IMPORTANT NOTE: As reference point position will be accepted signal peak position.

Step2. Access the TCG submenu and activate POINT function by pressing  button. While the Gate is lined up over the first reference echo record the first point by pressing  button. The “1” value will appear opposite “all” title in the bottom line of POINT function box.

Note that the largest echo to cross the A-Gate will be treated as the reference echo. The gain value at which this point is recorded becomes the “baseline” gain value.

Step 3: Continue to take additional reference points, following steps 1 and 2, up to a maximum of 10 points (note that at least two reference points are required).

Step 4: Note that stored DAC reference points can be edited as described in Section 5.3

NOTE: DAC curve and status (ON/OFF, TCG OR DAC) will be stored with data set. When recalled, curve status will be the same as when it was stored. For example, if DAC is active when a data set is stored, it will be active when that data set is recalled.



5.2.2 Working with DAC

In DAC mode the instrument uses the user-input reference points to create a curve representing the amplitudes of echoes representing same-size reflectors at varying material depth. The recorded reference point data is stored until replaced or edited.

To operate in DAC mode:

Step 1. Be sure what TCG mode is turned off. ( not displayed). I

Step 2. With the DISPLAY submenu accessed, select the TCG CURVE function by pressing  button.



Step3. Change function value to **DAC** by pressing   buttons. Available values are:

- TCG** – to display TCG curve
- DAC** – to display DAC curve
- NO** – to not display any curves

The DAC curve is appears on display. The DAC maximum amplitude will be equal **DAC AMPLITUDE** function value, which set up in Additional Menu.

To set alarm mode triggered by DAC:



Step 1. Activate MODE function in ALARM submenu by pressing  button.

Step2. Change function value to **BY DAC** using   buttons.

To measure amplitude as a dB difference between the echo’s peak and the DAC curve:





Step 1. Check up what ALARM-MODE function value set to **BY DAC**.





Step 2. Activate READING function in MEASURE submenu by pressing  button





Step 2. Change measure type to **H, dB** by pressing   buttons.

5.3 Editing DAC Curve and TCG Reference Points

After reference points are recorded, their values may be manually adjusted, or new points may be manually input (as long as the total number does not exceed 10 points). To edit points:

Step 1. Activate POINT function in TCG submenu by pressing  button and select point by pressing   buttons. Deactivate POINT function by pressing  button

Step 2. Activate POSITION function by pressing  button and correct point position by pressing   buttons. Deactivate POSITION function by pressing  button

Step 3. Activate TCG GAIN function by pressing  button and correct point gain by pressing   buttons. Deactivate TCG GAIN function by pressing  button

Step 5. Repeat steps 1-3 for other points if needed.

To create new point:



Step 1. Activate POINT function in TCG submenu by pressing  button

Step 2. Add new point by pressing  button.

Note: *If no echo in a-gate or TCG is on - appended new point will automatically have 10 μ s more position and 5 dB more TCG gain than last reference point.*

To delete point:

Step 1. Activate POINT function in TCG submenu by pressing  button

Step 2. Select point by pressing   buttons.

Step 3. Delete point by pressing and holding  button during at least 3 sec. *Note: horn will sound than point will deleted.*

To delete all reference point:

Step 1. Activate POINT function in TCG submenu by pressing  button

Step 2. Delete all points by pressing and holding  button during at least 10 sec. *Note: horn will sound than point will deleted.*

